

## Strikotherm BV

Postbus 52  
Lissenveld 9-13  
4940 AB Raamsdonksveer  
The Netherlands

Tel: 0031 162 514 750 Fax: 0031 162 522 483  
e-mail: info@strikotherm.nl  
website: www.strikotherm.nl



Agrément Certificate  
**10/4774**  
Product Sheet 2

## STRIKOTHERM EXTERNAL WALL INSULATION SYSTEMS

## STRIKOTHERM EPS EXTERNAL WALL INSULATION SYSTEMS

### PRODUCT SCOPE AND SUMMARY OF CERTIFICATE

This Certificate relates to Strikotherm EPS External Wall Insulation Systems, an external wall insulation system, which is suitable for use on new or existing domestic and non-domestic buildings.

#### AGRÉMENT CERTIFICATION INCLUDES:

- factors relating to compliance with Building Regulations where applicable
- factors relating to additional non-regulatory information where applicable
- independently verified technical specification
- assessment criteria and technical investigations
- design considerations
- installation guidance
- regular surveillance of production
- formal three-yearly review.

#### KEY FACTORS ASSESSED

**Thermal performance** — the systems can be used to achieve typical wall U values between 0.17 and 0.64  $\text{W}\cdot\text{m}^{-2}\cdot\text{K}^{-1}$  (see section 5).

**Strength and stability** — the systems can adequately resist wind loads and in certain applications impact damage (see section 6).

**Behaviour in relation to fire** — the systems are classified as combustible but the render finishes have a classification 'B-s1,d0' (class O or 'low risk' in Scotland) external surface rating. Cavity barriers (fire break) are required at each floor level above the first floor level, starting with the second storey (see section 7).

**Condensation** — the systems can contribute to limiting the risk of surface and interstitial condensation (see section 10).

**Durability** — with appropriate care, the systems should remain effective for at least 30 years (see section 12).



The BBA has awarded this Agrément Certificate to the company named above for the systems described herein. These systems have been assessed by the BBA as being fit for their intended use provided they are installed, used and maintained as set out in this Certificate.

On behalf of the British Board of Agrément

Chris Hunt  
Head of Approvals — Physics

Greg Cooper  
Chief Executive

Date of First issue: 13 August 2010

*The BBA is a UKAS accredited certification body — Number 113. The schedule of the current scope of accreditation for product certification is available in pdf format via the UKAS link on the BBA website at [www.bbacerts.co.uk](http://www.bbacerts.co.uk)*

*Readers are advised to check the validity and latest issue number of this Agrément Certificate by either referring to the BBA website or contacting the BBA direct.*

British Board of Agrément  
Bucknalls Lane  
Garston, Watford  
Herts WD25 9BA

tel: 01923 665300  
fax: 01923 665301  
e-mail: [mail@bba.star.co.uk](mailto:mail@bba.star.co.uk)  
website: [www.bbacerts.co.uk](http://www.bbacerts.co.uk)

©2010

# Regulations

In the opinion of the BBA, the StrikoTherm EPS External Wall Insulation Systems, if used in accordance with the provisions of this Certificate, will meet or contribute to meeting the relevant requirements of the following Building Regulations:



## The Building Regulations 2000 (as amended) (England and Wales)

<b>Requirement:</b> A1	<b>Loading</b>
Comment:	The systems can sustain and transmit wind loads to substrate wall. See section 6.1 of this Certificate.
<b>Requirement:</b> B4(1)	<b>External fire spread</b>
Comment:	The systems are classified B-s1,d0 or C-s2,d0 and therefore can meet this Requirement. See sections 7.1 to 7.4 of this Certificate.
<b>Requirement:</b> C2(b)	<b>Resistance to moisture</b>
Comment:	The systems provide a degree of protection against rain ingress. See sections 3.5, 9.3 and 9.4 of this Certificate.
<b>Requirement:</b> C2(c)	<b>Resistance to moisture</b>
Comment:	The systems contribute to minimising the risk of interstitial and surface condensation. See sections 10.1 and 10.3 of this Certificate.
<b>Requirement:</b> L1(a)(i)	<b>Conservation of fuel and power</b>
Comment:	The systems can contribute to meeting this requirement. See section 5 of this Certificate.
<b>Requirement:</b> Regulation 7	<b>Materials and workmanship</b>
Comment:	The systems are acceptable. See section 12.1 and the <i>Installation</i> part of this Certificate.



## The Building (Scotland) Regulations 2004 (as amended)

<b>Regulation:</b> 8(1)(2)	<b>Fitness and durability of materials and workmanship</b>
Comment:	The system can contribute to a construction meeting this Regulation. See sections 11.1, 12.1 and the <i>Installation</i> part of this Certificate.
<b>Regulation:</b> 9	<b>Building standards — construction</b>
<b>Standard:</b> 1.1	<b>Structure</b>
Comment:	The systems can sustain and transmit wind loads to the substrate wall. See section 6.1 of this Certificate.
<b>Standard:</b> 2.6	<b>Spread to neighbouring buildings</b>
Comment:	The systems incorporate materials which would not be classed as 'non-combustible'. Completed walls, therefore, should be regarded as unprotected areas as defined in this Standard, with reference to clauses 2.6.4 <sup>(1)(2)</sup> . See sections 7.1 to 7.3 of this Certificate.
<b>Standard:</b> 2.7	<b>Spread on external walls</b>
Comment:	The systems incorporate materials which would not be classed as 'non-combustible' as defined in this Standard, with reference to clause 2.7.1 <sup>(1)(2)</sup> and Annex 2A <sup>(1)</sup> . See section 7.4 of this Certificate.
<b>Standard:</b> 3.10	<b>Precipitation</b>
Comment:	Walls insulated with the systems will provide a degree of protection against rain ingress satisfying this Standard, with reference to clause 3.10.1 <sup>(1)(2)</sup> and 3.10.2 <sup>(1)(2)</sup> . See sections 3.5, 9.3 and 9.4 of this Certificate.
<b>Standard:</b> 3.15	<b>Condensation</b>
Comment:	Walls insulated with the systems contribute to minimising the risk of interstitial and surface condensation satisfying this Standard, with reference to clauses 3.15.1 <sup>(1)</sup> , 3.15.4 <sup>(1)</sup> and 3.15.5 <sup>(1)</sup> . See sections 10.2 and 10.3 of this Certificate.
<b>Standard:</b> 6.1(b)	<b>Carbon dioxide emissions</b>
<b>Standard:</b> 6.2	<b>Buildings insulation envelope</b>
Comment:	The systems can contribute to satisfying these Standards, with reference to clauses (or parts of) 6.1.1 <sup>(1)</sup> , 6.1.2 <sup>(1)(2)</sup> , 6.1.3 <sup>(2)</sup> , 6.1.5 <sup>(2)</sup> , 6.1.6 <sup>(1)</sup> , 6.2.1 <sup>(1)(2)</sup> , 6.2.3 <sup>(1)(2)</sup> , 6.2.4 <sup>(2)</sup> , 6.2.6 <sup>(1)(2)</sup> , 6.2.7 <sup>(1)(2)</sup> , 6.2.8 <sup>(2)</sup> , 6.2.9 <sup>(1)(2)</sup> , 6.2.10 <sup>(1)(2)</sup> , 6.2.11 <sup>(1)</sup> , 6.2.12 <sup>(2)</sup> and 6.2.13 <sup>(1)</sup> . See section 5 of this Certificate.
	(1) Technical Handbook (Domestic).
	(2) Technical Handbook (Non-Domestic).



## The Building Regulations (Northern Ireland) 2000 (as amended)

<b>Regulation:</b> B2	<b>Fitness of materials and workmanship</b>
Comment:	The systems are acceptable. See section 12.1 and the <i>Installation</i> part of this Certificate.
<b>Regulation:</b> B3(2)	<b>Suitability of certain materials.</b>
Comment:	The systems are acceptable. See section 11.1 of this Certificate.
<b>Regulation:</b> C4(b)	<b>Resistance to ground moisture and weather</b>
Comment:	Walls insulated with the systems provide a degree of protection against rain ingress and contribute to satisfy this Regulation. See sections 3.5, 9.3 and 9.4 of this Certificate.
<b>Regulation:</b> C5	<b>Condensation</b>
Comment:	Walls insulated with the systems contribute to minimising the risk of interstitial and surface condensation satisfying this Regulation. See section 10.3 of this Certificate.

Regulation:	D1	Stability
Comment:	The systems can sustain and transmit wind loads to the substrate wall. See section 6.1 of this Certificate.	
Regulation:	E5(a)	External fire spread
Comment:	The systems have a Bs-1,d0 or C-s2,d0 classification and can satisfy this Regulation. See sections 7.1 to 7.4 of this Certificate.	
Regulation:	F2(a)(i)	Conservation measures
Regulation:	F3(2)	Target carbon dioxide Emissions Rate
Comment:	The systems can contribute to satisfying these Regulations. See section 5 of this Certificate.	

## Construction (Design and Management) Regulations 2007

## Construction (Design and Management) Regulations (Northern Ireland) 2007

Information in this Certificate may assist the client, CDM co-ordinator, designer and contractors to address their obligations under these Regulations.

See section: 2 Delivery and site handling (2.1) of this Certificate.

# Non-regulatory Information

## NHBC Standards 2010

NHBC accepts the use of the Strikothersm EPS External Wall Insulation Systems, when installed and used in accordance with this Certificate, in relation to *NHBC Standards, Chapter 6.9 Curtain walling and cladding*.

# General

These systems are supplied in the UK by:

SAS (Europe) Ltd  
 Cheriton Bishop  
 Exeter  
 EX6 6JE  
 Tel: 01647 24620 Fax: 01647 24020  
 e-mail: sales@sas-europe.com  
 website: www.sas-europe.com

# Technical Specification

## 1 Description

1.1 The Strikothersm EPS External Wall Insulation Systems, are an external wall insulation system, using rigid expanded polystyrene (EPS) board, mechanical fixing systems, adhesive, a glass fibre reinforced undercoat, basecoat and textured finish coats. This Product Sheet covers the systems shown in Table 1.

Table 1 Strikothersm EPS MW External Wall Insulation Systems

System	Insulation material	Adhesive	Basecoat	Mesh	Primer	Finish
Strikothersm 100 GW	EPS	Strikothersm GG	Strikothersm GW FLEX	Reinforcing Mesh	BGI	BGI Plaster
FLEX-EPS	EPS	Strikothersm GG	Strikothersm GW FLEX	Reinforcing Mesh	BGI	Silicone Plaster
Strikothersm 100 – 200	EPS	Strikothersm GG	Strikothersm GG	Reinforcing Mesh	BGI	BGI Plaster
GG EPS	EPS	Strikothersm GG	Strikothersm GG	Reinforcing Mesh	BGI	Silicone Plaster
	EPS	Strikothersm GG	Strikothersm GG	Reinforcing Mesh	Silicate	Silicate Plaster
	EPS	Strikothersm GG	Strikothersm GG	Reinforcing Mesh	Variostar	Variostar
Strikothersm 100 – 200	EPS	Strikothersm GW	Strikothersm GW	Reinforcing Mesh	BGI	BGI Plaster
GW EPS	EPS	Strikothersm GW	Strikothersm GW	Reinforcing Mesh	BGI	Silicone Plaster
	EPS	Strikothersm GW	Strikothersm GW	Reinforcing Mesh	Silicate	Silicate Plaster
	EPS	Strikothersm GW	Strikothersm GW	Reinforcing Mesh	Variostar	Variostar
Strikothersm 100 – 200	EPS	Strikothersm GW	Strikothersm GW PLUS	Reinforcing Mesh	BGI	BGI Plaster
GW PLUS EPS	EPS	Strikothersm GW	Strikothersm GW PLUS	Reinforcing Mesh	BGI	Silicone Plaster
	EPS	Strikothersm GW	Strikothersm GW PLUS	Reinforcing Mesh	Silicate	Silicate Plaster
	EPS	Strikothersm GW	Strikothersm GW PLUS	Reinforcing Mesh	Variostar	Variostar

1.2 The systems (see Figure 1) comprise:

- EPS Insulation Board — 500 mm by 1000 mm in a range of thicknesses between 40 mm and 200 mm, with a (nominal) minimum density of 14 – 17 kg·m<sup>-3</sup> and a minimum tensile strength of 70 kN·m<sup>-2</sup>. Boards are manufactured to comply with the requirements of factory-prefabricated expanded polystyrene (EPS) material to BS EN 13163 : 2001
- Strikothersm Adhesive and Basecoat Mortar GW FLEX — a basecoat of ready to use paste based on resin binder (non cementitious) with nominal application thickness 4 mm
- Strikothersm Adhesive and Basecoat Mortar GG — a basecoat of cement based powder plaster requiring addition of about 26% in weight water with nominal application thickness of 4 mm

- Strikothersm Adhesive and Basecoat Mortar GW — a basecoat of cement based powder plaster requiring addition of about 26% in weight water with nominal application thickness of 4 mm
- Strikothersm Adhesive and Basecoat Mortar GW PLUS — a basecoat of cement based powder plaster requiring addition of about 26% in weight water with nominal application thickness of 4 to 7 mm
- Strikothersm Reinforcing Mesh — a 1 metre wide, woven glass fibre reinforcing mesh (embedded in the basecoat) with alkali and slide-resistant polymer coating, nominal weight of about 165 g/m<sup>2</sup>, mesh size 4 mm x 4 mm and thickness less than 1 mm
- Strikothersm BGI Primer — a key coat of resin binder
- Strikothersm Silicate Primer — a key coat of resin binder
- Strikothersm Silicone Primer — a key coat of resin binder
- Strikothersm BGI Plaster — a finishing coat of ready to use paste based on vinyl/acrylic binder, with particle size 1.5, 2.0 and 3.0 mm and thickness equal to particle size
- Strikothersm Silicate Plaster — a finishing coat of ready to use paste based on silicate binder, with particle size 1.5, 2.0 and 3.0 mm and thickness equal to particle size
- Strikothersm Silicone Plaster — a finishing coat of ready to use paste based on styrol acryl-silicone resin binder, with particle size 1.5, 2.0 and 3.0 mm and thickness equal to particle size
- Strikothersm Variostar — a finishing coat of cement based powder plaster requiring addition of about 30% in weight water, with particle size 1.0, 2.0 and 3.0 mm and thickness equal to particle size.

Figure 1 Strikothersm EPS External Wall Insulation Systems

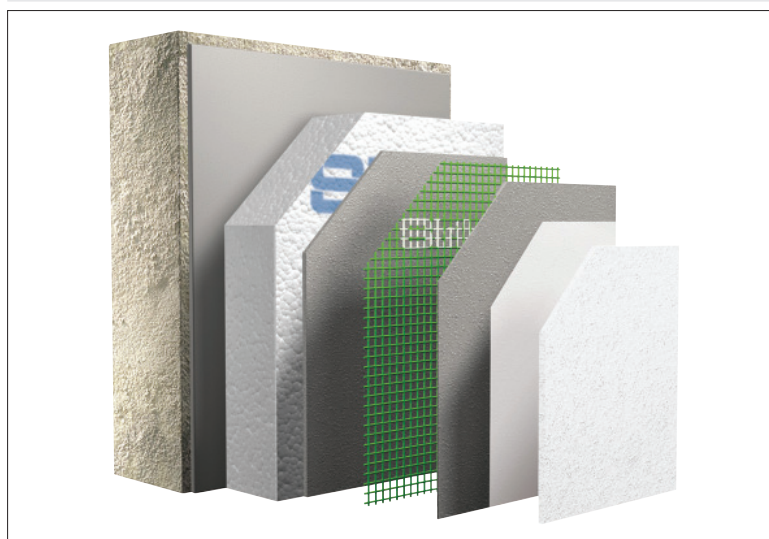

### 1.3 Ancillary items used but outside the scope of this Certificate include:

- supplied by the Certificate holder:

Protektor PVC Profiles

- starter track SPit + ASPit
- mesh angle bead profile NMAB
- expansion joint profile EX

ProBead UK Ltd BBA 06/4382

- angled bead profiles SAB, WAB
- stop bead profiles 3SB, W3SB
- Bellcast drip profiles 3BC, W3BC

Supplementary mechanical fixing anchors

- Ejothersm ST U
- Ejothersm STR U
- Ejothersm NT U
- Ejothersm NTK U
- Ejothersm SDM Tplus

- supplied by other suppliers that are required to ensure that the completed construction complies with the building regulations and is fit for purpose:

- Strikothersm fibre mesh angle
- Strikothersm fibre-band
- Strikothersm seal tape
- Strikothersm bitumen emulsion.

## 2 Delivery and site handling

2.1 The insulation is delivered to site in shrink-wrapped polythene packs which carry the manufacturer's and product identification marks and batch numbers.

2.2 Components are delivered to site in the quantities and packages as listed in Table 2. Each package carries the manufacturers and product's identification and batch number.

Table 2 Component supply details

Component	Form	Weight/Quantity	Package type
<b>Base coat</b>			
Strikotherm Adhesive and Basecoat Mortar GW FLEX	paste	25 kg	bucket
Strikotherm Adhesive and Basecoat Mortar GG	powder	25 kg	paper bag
Strikotherm Adhesive and Basecoat Mortar GW	powder	25 kg	paper bag
Strikotherm Adhesive and Basecoat Mortar GW PLUS	powder	20 kg	paper bag
<b>Glass Fibre mesh</b>			
Strikotherm Reinforcing Mesh	fibre	50 m	1 m wide rolls
<b>Primer</b>			
Strikotherm BGI Primer	liquid	22 kg	bucket
Strikotherm Silicate Primer	liquid	22 kg	bucket
Strikotherm Silicone Primer	liquid	22 kg	bucket
<b>Finish</b>			
Strikotherm BGI Plaster	paste	17 kg	bucket
Strikotherm Silicate Plaster	paste	17 kg	bucket
Strikotherm Silicone Plaster	paste	17 kg	bucket
Strikotherm Variostar	powder	25 kg	paper bag

2.3 Bagged materials must be stored in dry conditions, protected from the weather and against moisture during transport and storage.

2.4 All components should be protected against damage.

2.5 The insulation boards should be stored on a firm, clean, level base, off the ground. They must be protected from prolonged exposure to sunlight by storing opened packs under cover in dry conditions or re-covering with opaque polythene sheeting.

2.6 Care must be taken when handling the insulation boards to avoid both damage and contact with solvents or bitumen products. The boards must not be exposed to open flame or other ignition sources.

2.7 Liquid products should be stored in a safe area, under cover, and must be protected from excessive heat and frost at all times.

## Assessment and Technical Investigations

The following is a summary of the assessment and technical investigations carried out on the Strikotherm EPS External Wall Insulation Systems.

## Design Considerations

### 3 General

3.1 The Strikotherm EPS External Wall Insulation Systems, comprise rigid EPS board, mechanical fixings, adhesive, basecoat with embedded glass fibre reinforcement mesh and finish coats with a textured finish. The systems are applied to the outside of external walls of masonry, dense or no-fines concrete construction and are suitable for use on new or existing domestic and non-domestic buildings with no storey more than 18 m above ground level.

3.2 The systems are effective in reducing the thermal transmittance (U value) of the walls of new and existing buildings. It is essential that the detailing techniques specified in this Certificate are carried out to a high standard, if the ingress of water into the insulation is to be avoided and the full thermal benefit obtained from treatment with the system.

3.3 The systems will improve the weather resistance of a wall and provide a decorative finish. However, it may be installed only where other routes for moisture penetration have been dealt with separately and where there are no signs of dampness on the inner surface of the wall, other than those caused solely by condensation. The systems can be used to overcome condensation associated with the internal wall surface.

3.4 Existing buildings, subject to national Building Regulations, should have wall surfaces in accordance with section 1.3 *Site survey and preliminary work* in the *Installation* part of this Certificate.

3.5 New walls subject to national Building Regulations should be constructed in accordance with the relevant recommendations of:



- BS EN 1996-2 : 2006
- BS 8000-3 : 2001.

3.6 Other walls, not subject to regulatory requirements should also be built in accordance with the requirements in section 3.4.

3.7 When using the systems, consideration must be given to the overall design to minimise the risk of condensation and the recommendations of BS 5250 : 2002 should be followed.

## 4 Practicability of installation

The systems should only be installed by installers who have been trained and approved by the Certificate holder (see section 14).

## 5 Thermal performance

5.1 Calculations of thermal transmittance (U value) should be carried out in accordance with BS EN ISO 6946 : 2007 and BRE report *Conventions for U-value calculations* (BR 443 : 2006), using the insulations declared thermal conductivity ( $\lambda_{90/90}$ ) in Table 3.

Table 3 Thermal conductivities of the boards

EPS grade	Thermal conductivity ( $W \cdot m^{-1} \cdot K^{-1}$ )
EPS 70	0.038
EPS 70E	0.038
Platinum EPS 70E	0.030

5.2 The U value of a wall will depend on the selected insulation thickness, fixing method and the insulating value of the masonry substrate and its internal finish. Calculated U values for example constructions are given in Table 4 and typical design U values in Tables 5 and 6.

Table 4 Example wall U values ( $W \cdot m^{-1} \cdot K^{-1}$ )

Insulation thickness (mm)	EPS70 & EPS70E <sup>(1)</sup>		EPS70 Platinum <sup>(1)</sup>	
	Dense concrete block <sup>(2)</sup>	Brickwork <sup>(3)</sup>	Dense concrete block <sup>(2)</sup>	Brickwork <sup>(3)</sup>
50	0.64	0.56	0.53	0.48
100	0.37	0.34	0.31	0.29
150	0.27	0.25	0.22	0.21
200	0.21	0.20	0.18	0.17

(1) Includes eight fixings per m<sup>2</sup>

(2) 200mm dense concrete block at  $\lambda=1.75 W \cdot m^{-1} \cdot K^{-1}$

(3) 220mm brickwork at  $\lambda=0.56 W \cdot m^{-1} \cdot K^{-1}$

Table 5 Typical design U values for walls — England and Wales, and Northern Ireland

Construction type	U value ( $W \cdot m^{-2} \cdot K^{-1}$ )
Existing building, new wall	0.30
New build limit	0.35
Existing building, renovated, retained or replaced wall	0.35
Notional building	0.35

(1) Alternative or flexible approaches are given in relevant documents supporting the national Building Regulations.

Table 6 Typical design U values for walls — Scotland

Construction type	U value ( $W \cdot m^{-2} \cdot K^{-1}$ )
Notional dwelling	0.20
Simplified approach, fuel package 6	0.20
Simplified approach, fuel packages 1-5	0.25
Shell and fit out	0.25
Mean for new extensions, conversions and alterations	0.27
Mean for stand-alone buildings less than 50 m <sup>2</sup>	0.27
Limit mean for new-build	0.30
Notional non dwelling	0.30

(1) Alternative or flexible approaches are given in relevant documents supporting the national Building Regulations.

## Junctions

5.3 The systems can maintain, or contribute to maintaining, continuity of thermal insulation at junctions. Example details shown in Figure 2 are acceptable for newly constructed walls (additionally altered walls in Scotland) to existing buildings and will allow use of default psi values for Accredited Construction Details in carbon emission calculations. Detailed guidance on maintaining insulation continuity at other junctions and on limiting heat loss by air infiltration can be found in:

**England and Wales** — Accredited Construction Details (version 1.0)

**Scotland** — Accredited Construction Details (Scotland)

**Northern Ireland** — Accredited Construction Details (version 1.0).

Figure 2 Junction details (all dimensions in mm)

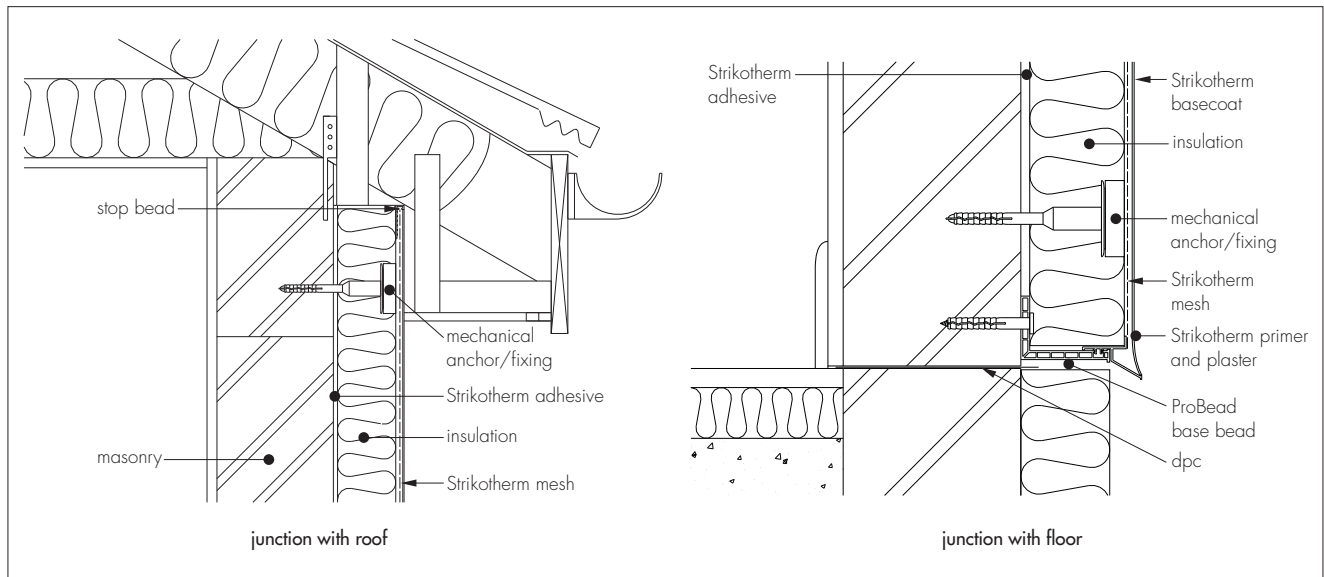

## 6 Strength and stability

### General



6.1 When installed on suitable walls, the systems can adequately transfer self weight, and negative and positive (suction and pressure) wind loads to the wall.

6.2 The ultimate wind load to be resisted by the systems should be determined by calculating the wind load in accordance with BS EN 1991-1-4 : 2005 or BS 6399-2 : 1997 and multiplying by a load factor of 1.5 (as recommended in EN 1990 : 2002). Special consideration should be given to locations with high wind-load pressure coefficients (additional fixings or adhesive may be necessary).

6.3 Assessment of structural performance for individual installations should be carried out by a suitably qualified engineer or other appropriately qualified person to confirm that:

- The substrate wall has adequate strength to resist the additional loads that may be applied as a result of installing the systems ignoring any positive contribution that may occur from the systems
- The proposed system and associated fixing layout provides adequate resistance to negative wind loads (based on the results of the site investigation and design data given in this section).

6.4 The bond strength between the adhesive/basecoat and the insulation may be taken as well in excess of any negative pressures likely to occur in the UK. Examples of wind load calculations can be seen in Table 7.

**Table 7 Example wind loads calculations**

Mechanically fixed systems with 100% supplementary adhesive

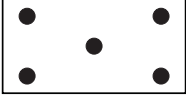
Calculated wind load (Pa)		<b>900<sup>(1)</sup></b>
Ultimate wind load (Pa)		1350
Required wind load resistance per panel (N)		675
Typical pull out resistance of fixing from substrate (N)		550
<b>Fixing pattern example (a)</b>		
	Design pull out resistance of fixings (N) Design pull over resistance of fixings (N)	<b>733<sup>(1)</sup></b> 533
	Design limited by? Fixing pattern suitable?	The pull over of insulation from the head of a fixing NO
<b>Fixing pattern example (b)</b>		
	Design pull out resistance of fixings (N) Design pull over resistance of fixings (N)	<b>917<sup>(1)</sup></b> 703
	Design limited by? Fixing pattern suitable?	The pull over of insulation from the head of a fixing YES

(1) Bold italicised values are example figures only, to illustrate the calculation process. They must be determined for each site in accordance with sections 6.2 and 6.5.

**Mechanically fixed systems with 100% supplementary adhesive**

6.5 The resistance to negative wind load should be taken as the lesser of the anchor pull over and pull out strengths determined as follows:

- a) the panels resistance to pulling over of the defined ETICS anchors, may be taken from Table 8. In the absence of a formal requirement, a safety factor of 3 should be applied to this value. The pull over resistance of other fixings should be established in accordance with ETAG 004 : 2000 section 5.1.4.3.1
- b) the pull out strength of the fixings should be determined on site as described in section 13.9. The design pull out strength should be taken as the lowest of the five results divided by a safety factor of 3.

If the minimum value established from (a) or (b) is less than the ultimate wind load determined in accordance with section 6.2 other fixing arrangements should be considered.

**Table 8 Design pull over resistance of fixings (N)<sup>(1)</sup>**

	Fixing head diameter
	60 mm
Edge fixings (N)	400
Other fixings (N) <sup>(2)</sup>	510

(1) This data relates to the following Ejoyt fixings: Ejotherm ST U (ETA 02/0018), Ejotherm STR U<sup>(3)</sup> (ETA 04/0023), Ejotherm NT U (ETA 05/0009), Ejotherm NTK U (ETA 07/0026), Ejoyt SDM T Plus (ETA 04/0064).

(2) Minimum distance to the edge of the board = 100 mm.

(3) For STU:

- thickness ≥60 mm for surface mounting
- thickness ≥80 mm for deep mounting with a maximum depth of die of 5 mm
- thickness ≥100 mm for deep mounting with a maximum depth of die of 20 mm

## Impact resistance

6.6 The systems are suitable for use in areas as defined in Table 9 below.

System	Insulation material	Adhesive	Basecoat	Mesh	Primer	Finish	Impact resistance <sup>(1)</sup>
Strikotherm 100 GW FLEX-EPS	EPS	Strikotherm GG	Strikotherm GW Flex	Reinforcing Mesh	BGI	BGI Plaster	B
	EPS	Strikotherm GG	Strikotherm GW Flex	Reinforcing Mesh	BGI	Silicone Plaster	B
Strikotherm 100 – 200 GG EPS	EPS	Strikotherm GG	Strikotherm GG	Reinforcing Mesh	BGI	BGI	C
	EPS	Strikotherm GG	Strikotherm GG	Reinforcing Mesh	BGI	Silicone Plaster	C
	EPS	Strikotherm GG	Strikotherm GG	Reinforcing Mesh	Silicate	Silicate Plaster	C
	EPS	Strikotherm GG	Strikotherm GG	Reinforcing Mesh	Variostar	Variostar	C <sup>(2)</sup>
Strikotherm 100 – 200 GW EPS	EPS	Strikotherm GW	Strikotherm GW	Reinforcing Mesh	BGI	BGI	C
	EPS	Strikotherm GW	Strikotherm GW	Reinforcing Mesh	BGI	Silicone Plaster	F <sup>(2)</sup>
	EPS	Strikotherm GW	Strikotherm GW	Reinforcing Mesh	Silicate	Silicate Plaster	C
	EPS	Strikotherm GW	Strikotherm GW	Reinforcing Mesh	Variostar	Variostar	C <sup>(2)</sup>
Strikotherm 100 – 200 GW PLUS EPS	EPS	Strikotherm GW PLUS	Strikotherm GW PLUS	Reinforcing Mesh	BGI	BGI	C
	EPS	Strikotherm GW PLUS	Strikotherm GW PLUS	Reinforcing Mesh	BGI	Silicone Plaster	C
	EPS	Strikotherm GW PLUS	Strikotherm GW PLUS	Reinforcing Mesh	Silicate	Silicate Plaster	C
	EPS	Strikotherm GW PLUS	Strikotherm GW PLUS	Reinforcing Mesh	Variostar	Variostar	C

(1) Categories from BS 8200 : 1985:

B = readily accessible to public and others with little incentive to exercise care. Chances of accident occurring and of misuse, for example, walls adjacent to pedestrian thoroughfares or playing fields when not in category A. Zone of wall up to 1.5 m above pedestrian or floor level.

C = accessible primarily to those with some incentive to exercise care. Some chance of accident occurring and of misuse, for example, walls adjacent to private open gardens. Back walls of balconies. Zone of wall up to 1.5 m above pedestrian or floor level.

F = above zone of normal impacts from people and not liable to impacts from thrown or kicked objects, for example, wall surfaces at higher positions than 1.5 m above pedestrian or floor level.

(2) Assessment based upon test results for mineral wool lamella and the results of small scale tests carried out by the ETA issuing organisation.

6.7 The impact resistance of the insulation system may be improved if a different type of reinforcing mesh is used. The use of different meshes is outside the scope of this Certificate; see the Certificate holder for more information in connection with this.

## 7 Behaviour in relation to fire



7.1 Strikotherm 100 - 200 GG EPS, Strikotherm 100 - 200 GW EPS and Strikotherm 100 - 200 GW PLUS EPS have the following classifications:

- EPS insulation Class E reaction to fire according to EN 13501-1 : 2007.
- External surface rating of system B-s1,d0 according to EN 13501-1 : 2007 (class 0 or 'low risk' in Scotland)
- Overall classification of system B-s1,d0

7.2 Strikotherm 100 GW FLEX-EPS has the following classifications:

- EPS insulation Class E reaction to fire according to EN 13501-1 : 2007
- External surface rating of system C-s2,d0 according to EN 13501-1 : 2007 (class 1 or 'medium risk' in Scotland)
- Overall classification of system C-s2,d0.

7.3 The documents supporting the national Building Regulations give full details of permissible heights and boundary conditions and should be referred to for project specific requirements, however, the following information is for guidance purposes:

### England, Wales and Northern Ireland

The systems are acceptable:

- one metre or more from a boundary
- less than one metre from a boundary for the systems in 7.1, provided the wall meets the relevant requirements for fire resistance from both sides and extent of unprotected areas
- on walls (a) or (b) up to storey heights of 18 m.

### Scotland

The systems are acceptable:

- more than one metre from a boundary, but must be included, with some minor exceptions, in the calculation of unprotected area
- on wall (a) up to storey heights of 18 m.

7.4 To limit the risk of fire spread between floors cavity barriers should be installed at each floor level above the first-floor level (ie starting with the second storey) as detailed in BRE report (BR 135) : 2003 *Fire Performance of External Insulation for Walls of Multi-storey Buildings*. See Figure 3. Vertical cavity barriers should also be installed in line with compartment walls.

Figure 3 Cavity barrier



7.5 In buildings not subject to the Building Regulations, it is recommended that designers should consider the use of the guidance given in section 7.4.

## 8 Proximity of flues and appliances

When the systems are installed in close proximity to certain flue pipes the relevant provisions of the national Building Regulations should be met:

**England and Wales** — Approved Document J

**Scotland** — Mandatory Standard 3.19, clause 3.19.4<sup>(1)(2)</sup>

(1) Technical Handbook (Domestic).

(2) Technical Handbook (Non-Domestic).

**Northern Ireland** — Technical Booklet L.

## 9 Rain penetration

9.1 The systems will provide a degree of protection against rain ingress, however, care should be taken to ensure that walls are adequately weathertight prior to the application of the systems.

9.2 Designers and installers should take particular care in detailing around openings, penetrations and movement joints to minimise the risk of rain ingress.

 9.3 BS EN 1996-2 : 2006 details the acceptable specifications for masonry units for durability in various exposure classes.

9.4 Guidance in BS 5628-3 : 2005, Table 11 indicates that externally insulated single leaf masonry walls (minimum 90 mm thick) are acceptable in exposure categories up to 'severe'.

## 10 Condensation

### Surface Condensation

 10.1 Walls will limit the risk of surface condensation adequately when the thermal transmittance (U value) does not exceed  $0.7 \text{ W}\cdot\text{m}^{-2}\cdot\text{K}^{-1}$  at any point and the junctions with other elements and openings comply with in section 5.3.

 10.2 Walls will adequately limit the risk of surface condensation when the thermal transmittance (U value) does not exceed  $1.2 \text{ W}\cdot\text{m}^{-2}\cdot\text{K}^{-1}$  at any point. Guidance may be obtained from Section 8 of BS 5250 : 2002 and BRE report (BR 262 : 2002) *Thermal insulation : avoiding risks*.

### Interstitial condensation

 10.3 Walls incorporating the systems will adequately limit the risk of interstitial condensation when they are designed and constructed in accordance with BS 5250 : 2002 (Section 8 and Annex D).

10.4 The water vapour resistance for the GW, GW PLUS, GW FLEX basecoats (with the render finish) and GG basecoat (with render finish) is not more than  $3 \text{ MN}\cdot\text{s}\cdot\text{g}^{-1}$  and  $0.4 \text{ MN}\cdot\text{s}\cdot\text{g}^{-1}$  respectively. The range of coverage was 6 mm to 8 mm.

10.5 The resistivity of the EPS boards can be taken as between  $100 - 200 \text{ MN}\cdot\text{s}\cdot\text{g}^{-1}\cdot\text{m}^{-1}$ .

## 11 Maintenance

 11.1 Regular checks should be made on the installed systems, particularly at joints, to ensure that ingress of water does not occur. This includes checks on joints in the systems and on any penetrations through the systems, such as those caused by external plumbing fittings, to identify leakage of rainwater into the system, enabling steps to be taken to correct the defects. Necessary repairs should be carried out immediately.

11.2 Damaged areas must be repaired using the appropriate components and the procedures detailed in the Certificate holder's installation instructions.

## 12 Durability



12.1 The systems should remain effective for at least 30 years, provided any damage to the surface finish is repaired immediately, and regular maintenance is undertaken. See section 11.

12.2 The textured finishes may become soiled in time; the rate depending on locality. The appearance may be restored by a suitable power wash. Care is required when using power washing equipment to avoid damage, particularly at joints, corners and drips.

12.3 If required, a compatible paint may be applied. However, care should be taken in selecting a paint specification that does not adversely affect the water vapour transmission or fire characteristics of the system. The advice of the Certificate holder should be sought.

## Installation

### 13 Site survey and preliminary work

13.1 A pre-installation survey of the property is carried out to determine suitability for treatment and necessary repairs to the building structure before application of the Strikotherm EPS External Wall Insulation Systems. The survey should include tests and an assessment and recommendation on the type and number of fastenings required in respect of the building's expected wind loading. A specification is prepared for each elevation of the building indicating:

- the position of starter track/basetrim bead
- where required, additional reinforcement mesh
- the position of beads
- detailing around windows, doors and at eaves
- dpc level
- exact position of expansion joints
- areas where flexible sealants must be used
- any alteration to existing external plumbing and other ancillary services
- where required, the position of fire barriers.

13.2 All necessary repairs to the building structure are completed before installation of the system is started.

13.3 Surfaces should be sound, clean and free from loose material. The flatness of surfaces must be checked; this may be achieved using a straight edge spanning the storey height. Any excessive irregularities, ie greater than 10 mm in 1 metre, must be made good prior to installation to ensure that the insulation boards are installed with a smooth, in-plane finished surface.

13.4 New buildings should be of sound masonry, dense or no-fines concrete construction.

13.5 Where surfaces are covered with an existing rendering it is essential that the bond between the background and the render is adequate. All loose areas should be hacked off and reinstated.

13.6 On existing buildings, purpose-made window sills must be fitted to extend beyond the finished face of the system. New buildings should incorporate suitably deep sills.

13.7 Internal wet work, e.g. screeding or plastering, should be completed and allowed to dry prior to the application of a system.

13.8 The condition of the external wall surface to receive the product is not a specific consideration, provided that the fastenings are anchored into a substrate capable of supporting the loads imposed by the external insulation and forces on it.

13.9 In every case, insulation boards are initially attached and bonded to the wall using a specified adhesive, followed by a selected, project specific, mechanical fastenings applied to a minimum depth into the substrate and to a given symmetrical pattern. Trial tests are conducted on the walls of the building to determine the pull out strength of the fastenings. The number of fastenings to be used is calculated using the test data for the specific fastenings, the relevant wind speed data for the site and, in the absence of a formal requirement, a safety factor of 3. Trial tests are conducted on the wall by the Certificate Holder or their Representative (see section 14) to determine the pull out resistance of the proposed mechanical fastenings, it is recommended to follow the minimum layout of fastenings according to the Certificate Holder.

13.10 Where required by the Local Fire Authority, and in any event, above the second floor level of the building, at least one fastening per full or part insulation board should be of a non combustible type to provide the increased duty that may be required in a fire. It is recommended to follow the fastening layout according to the Certificate Holder (see Figure 4).

Figure 4 Example layout of fixings

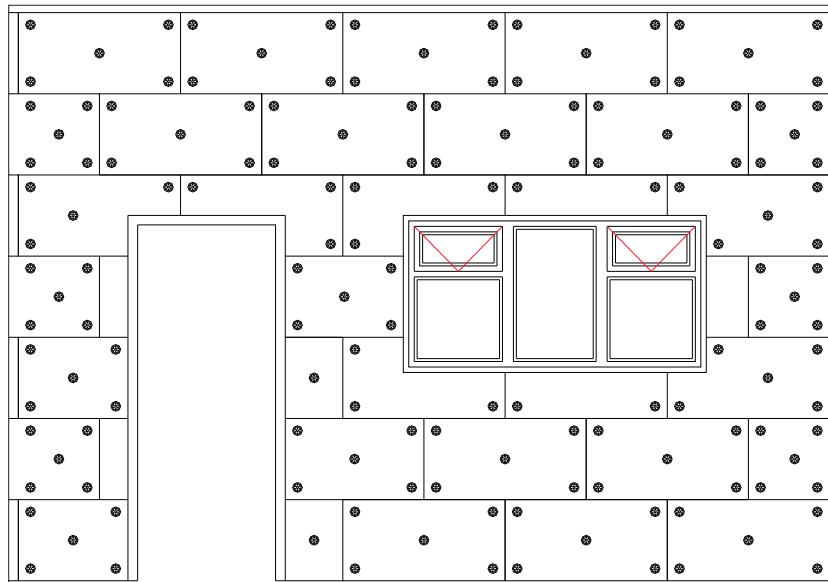

13.11 All modifications, such as provision for cavity barriers and fire stopping (see section 7) and necessary repairs to the building are completed before installation commences.

13.12 It is recommended that external plumbing and ancillary services be removed before Installation. Alterations may be made to underground drainage where appropriate, to accommodate repositioning of the plumbing on the finished face of the system.

## 14 Approved installers

The Certificate holder operates an Approved Installer Scheme for the system, under which installers are trained, approved and regularly reviewed by the Certificate holder, to demonstrate that they are competent to carry out installation of the system in accordance with this Certificate. Details of approved installers are available from the Certificate holder.

## 15 Procedure

### General

15.1 Application is carried out in accordance with the current installation instructions of the Certificate holder.

15.2 Weather conditions should be monitored to ensure correct application and curing conditions. Application of the undercoat and finishes should not be carried out at temperatures below 5°C or above 30°C, nor if exposure to frost is likely. The coating must be protected from rapid drying.

15.3 All rendering should be in accordance with the relevant recommendations of BS EN 13914-1 : 2005.

### Mechanically fixed systems with 100% supplementary adhesive

15.4 Adhesive is prepared by mixing 6 to 7 litres of clean water with every 25 kg bag.

15.5 Installation begins at the base of the wall above the dpc. A firm, horizontal support, either the starter track or a temporary timber batten, is used to mount the first row of boards. The starter track is installed as previously described.

15.6 If a temporary timber batten is to be used, a strip of mesh is partially adhered to the wall so that 300 mm of mesh is hanging from the starting line of the installation. Basecoat plaster is subsequently used to wrap the overhanging mesh around the lower edge and adhere it to the first row of insulation boards. All exposed edges of the insulation boards are protected in this manner.

15.7 The adhesive is applied over the entire rear face of the insulation board, using a notched trowel.

15.8 The boards must be pressed firmly against the wall and butted tightly together with the vertical joints staggered. Joints in the system greater than approximately 2 mm should be filled with slivers of insulation board or PU foam and any high spots or irregularities removed by lightly planing with a rasp over the whole surface.

15.9 In every case, selected, project specific, mechanical fastenings are installed through the insulation into the substrate, following the fixing pattern recommended by the Certificate holder.

### Reinforcing

15.10 The basecoat plasters are prepared in accordance with their respective Technical Data Sheets.

15.11 The prepared basecoat is applied to an approximate thickness of 4 mm over the insulation boards, using spray equipment or a stainless steel trowel. The basecoat is applied progressively working in 1 m sections in a vertical or horizontal direction.

15.12 The reinforcement mesh is immediately embedded into the wet basecoat, and overlapping at all mesh joints by not less than 100 mm. Corner details are reinforced using PVC mesh angle beads or armour angles.

15.13 Additional pieces of reinforcing mesh (300 mm by 300 mm) are used diagonally at the corners of openings (see Figure 5).

Figure 5 Additional reinforcement at openings

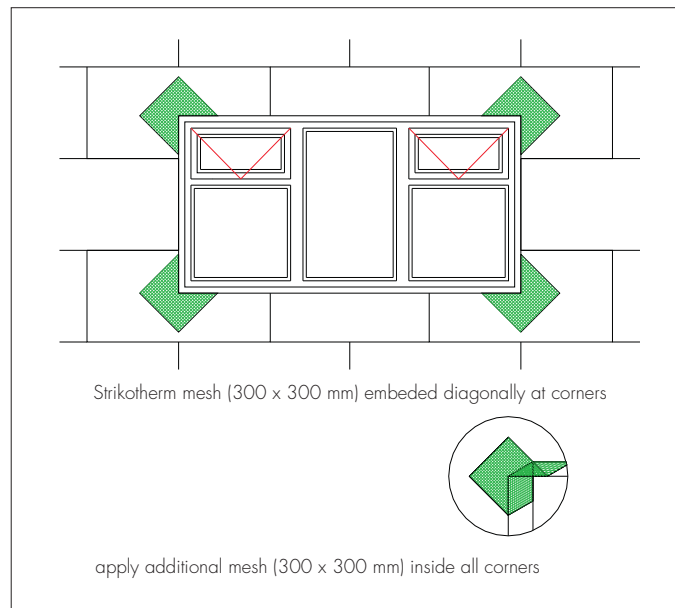

15.14 The mesh should be free of wrinkles and fully embedded in the basecoat with the mesh pattern not visible on the finished surface.

### Movement joints

15.15 Existing construction joints in the wall should be carried through the insulation system.

15.16 Additional expansion joints in the insulation system are determined by the Certificate holder at the time of initial survey. Each project is considered on its own merits and the Certificate holder will take into account construction format, building design and fenestration when determining the regularity and positioning of both vertical and horizontal expansion joints in the system (see Figure 6).

Figure 6 Movement joint

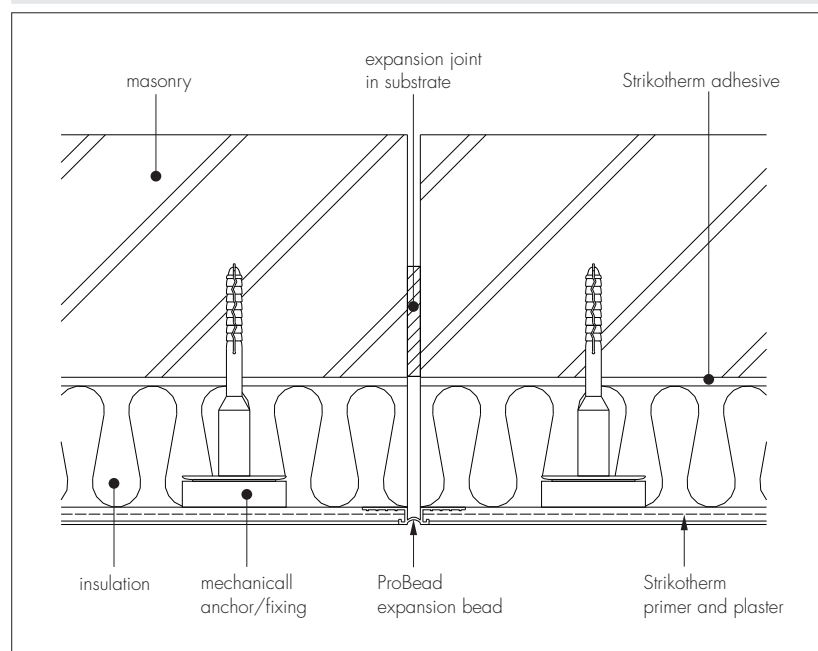

### Render finishing

15.17 The basecoat should be left to dry thoroughly before application of the decorative finish. Depending on conditions the drying time should be between 24 hours and 48 hours. In case the finishing coat is resin-based, the dried basecoat requires a pre-treatment with a primer according to the manufacturers guidelines. This primer should be left to dry thoroughly before application of the finishing.

15.18 The finish coat plasters are prepared in accordance with their respective Technical Data Sheets and are trowel applied in thicknesses from 1.5 mm to 6 mm (corresponding to the thickness of the grain) using a stainless steel trowel.

15.19 The finish coats should be allowed to dry thoroughly before paints are applied to any features.

15.20 Continuous surfaces must be completed without a break, so the coatings must always be applied to a wet edge.

15.21 At the top of walls the insulation boards must be protected by fitting under a soffit or similar projection and be sealed using seal tape.

15.22 At windows and doors the insulation should be continued around the reveals where there is sufficient clearance. New buildings should be built to allow this. Where there is insufficient clearance the basecoat, reinforcement mesh and render decorative finish should be continued into the reveal. The insulation system must be sealed around window frames and sills to give an elastic joint using seal/compri tape or, with a starter profile and sealant in uninsulated reveals (see Figure 7).

Figure 7 Window details

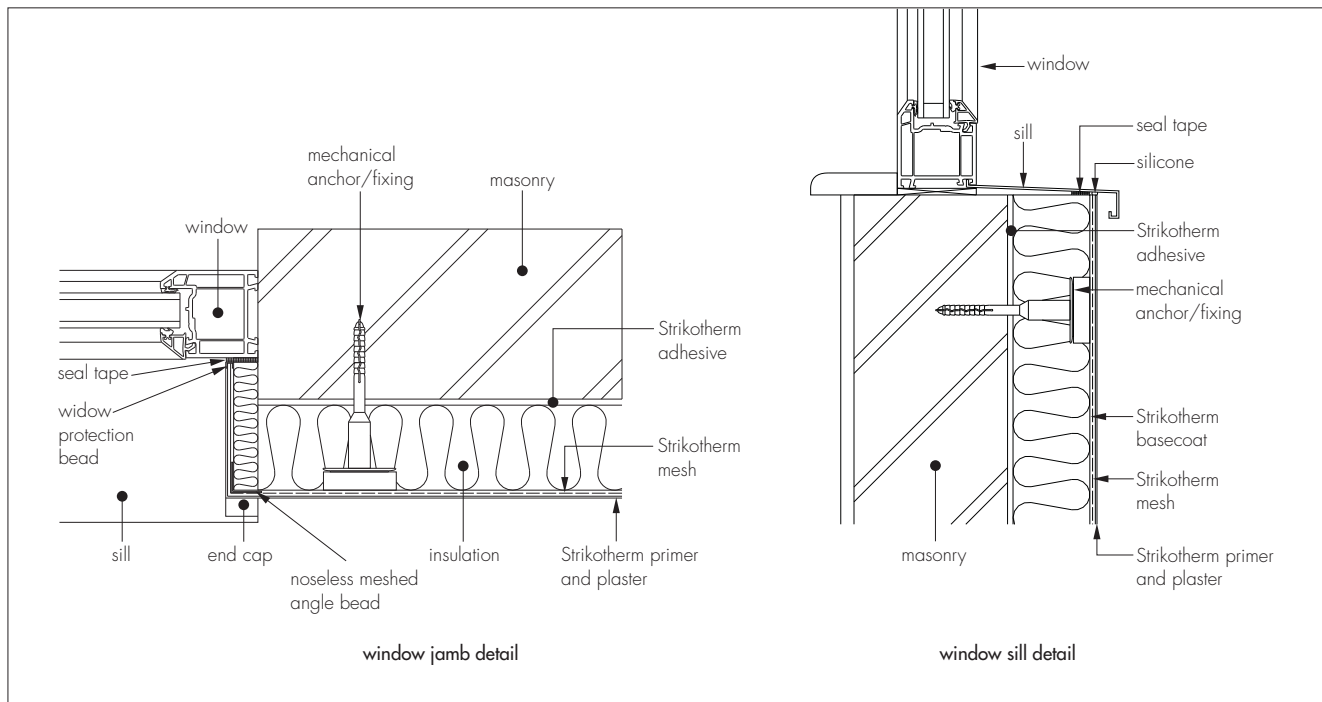

15.23 On completion external fittings are re-fixed to the substrate using suitable fixing pads previously installed in the systems.

15.24 On completion of the installation, external fittings, eg rainwater goods, are re-fixed through the system into the substrate.

## Technical Investigations

### 16 Tests

16.1 An examination was made of data relating to:

- water absorption (capillary action) to ETAG 004 : 2000
- bond strength after ageing to ETAG 004 : 2000
- thermal conductivity of insulation
- pull-out strength of anchor to ETAG 004 : 2000
- pull-through resistance of fixings from profiles to ETAG 004 : 2000
- glass fibre mesh – tearing strength and elongation of the reinforcing fabric to ETAG 004 : 2000
- adhesive and render characterisation test reports
- reaction to fire, class in accordance with EN 13501-1 : 2007
- hygrothermal behaviour to ETAG 004 : 2000
- resistance to hard body impact to ETAG 004 : 2000
- water vapour permeability to ETAG 004 : 2000
- release of dangerous substances to ETAG 004 : 2000
- bond strength between the basecoat and insulation product to ETAG 004 : 2000.

## 17 Investigations

17.1 The manufacturing process, the methods adopted for quality control of manufactured and bought-in components, and details of the quality and composition of the materials used, were examined.

17.2 An assessment of the risk of interstitial condensation was undertaken.

17.3 The practicability of installation and the effectiveness of detailing techniques were examined.

## Bibliography

BS 5250 : 2002 *Code of practice for control of condensation in buildings*

BS 5628-3 : 2005 *Code of practice for the use of masonry — Materials and components, design and workmanship*

BS 6399-2 : 1997 *Loading for buildings — Code of practice for wind loads*

BS 8000-3 : 2001 *Workmanship on building sites — Code of practice for masonry*

BS 8200 : 1985 *Code of practice for design of non-loadbearing external vertical enclosures of buildings*

BS EN 1991-1-4 : 2005 *Eurocode 1 : Actions on structures — General actions — Wind actions*

BS EN 1996-2 : 2006 *Eurocode 6 : Design of masonry structures — Design considerations, selection of materials and execution of masonry*

BS EN 13163 : 2001 *Thermal insulation products for buildings — Factory made products of expanded polystyrene (EPS) — Specification*

BS EN 13914-1 : 2005 *Design, preparation and application of external rendering and internal plastering — External rendering*

BS EN ISO 6946 : 1997 *Building components and building elements — Thermal resistance and thermal transmittance — Calculation method*

BS EN 1990 : 2002 *Eurocode — Basis of structural design*

EN 13501-1 : 2007 *Fire classification of construction products and building elements — Classification using test data from reaction to fire tests*

ETAG 004 : 2000 *Guideline for European Technical Approval of External Thermal Insulation Composite Systems with Rendering*

## 18 Conditions

18.1 This Certificate:

- relates only to the product/system that is named and described on the front page
- is granted only to the company, firm or person named on the front page — no other company, firm or person may hold or claim any entitlement to this Certificate
- is valid only within the UK
- has to be read, considered and used as a whole document — it may be misleading and will be incomplete to be selective
- is copyright of the BBA
- is subject to English law.

18.2 Publications and documents referred to in this Certificate are those that the BBA deems to be relevant at the date of issue or re-issue of this Certificate and include any: Act of Parliament; Statutory Instrument; Directive; Regulation; British, European or International Standard; Code of Practice; manufacturers' instructions; or any other publication or document similar or related to the aforementioned.

18.3 This Certificate will remain valid for an unlimited period provided that the product/system and the manufacture and/or fabrication including all related and relevant processes thereof:

- are maintained at or above the levels which have been assessed and found to be satisfactory by the BBA
- continue to be checked as and when deemed appropriate by the BBA under arrangements that it will determine
- are reviewed by the BBA as and when it considers appropriate.

18.4 In granting this Certificate, the BBA is not responsible for:

- the presence or absence of any patent, intellectual property or similar rights subsisting in the product/system or any other product/system
- the right of the Certificate holder to manufacture, supply, install, maintain or market the product/system
- individual installations of the product/system, including the nature, design, methods and workmanship of or related to the installation
- the actual works in which the product/system is installed, used and maintained, including the nature, design, methods and workmanship of such works.

18.5 Any information relating to the manufacture, supply, installation, use and maintenance of this product/system which is contained or referred to in this Certificate is the minimum required to be met when the product/system is manufactured, supplied, installed, used and maintained. It does not purport in any way to restate the requirements of the Health & Safety at Work etc Act 1974, or of any other statutory, common law or other duty which may exist at the date of this Certificate; nor is conformity with such information to be taken as satisfying the requirements of the 1974 Act or of any statutory, common law or other duty of care. In granting this Certificate, the BBA does not accept responsibility to any person or body for any loss or damage, including personal injury, arising as a direct or indirect result of the manufacture, supply, installation, use and maintenance of this product/system.